



# QD85U UNIVERSAL AC/DC INVERTER CONTROL SYSTEM FOR SPLIT AIR CONDITIONER

## 1. Preface

QD85U is our latest universal control system for AC/DC inverter split air conditioners.

Thank you for choosing this product, and it's our great pleasure to bring convenience for your daily life. Please read the user's manual carefully before using this control system, which will assist you to install and use the control system correctly.

## 2. Product Function Introduction

- 1) Parts of control system: ①universal indoor board, ②remote control, ③universal outdoor board.
- 2) Enable to drive strong AC/DC compressor.    3) Available for indoor brushless DC motor or PG motor    4) Enable to drive outdoor AC/DC fan motor.
- 5) Applicable for controlling electronic expansion valve.

## 3. Attentions before installation

- Please hire technicians with qualification for installation and do conduct power-on test before it. There is still high voltage in the PCBA board , within 3 minutes after power off. Please be careful.
- Please identify the air conditioner type(DC inverter or AC inverter) ,Users just need to use the gear 1 to select DC inverter or AC inverter.
- With 3 minutes' delay for protection, the compressor will restart after 3 minutes for stop or defrost.
- If the air conditioner works absolutely nosily, check three phases to see if there are cases of phase missing or phase dislocation. Ensure the maximum compressor working current is less than 110% of air conditioner rated current.
- Any damage due to improper installation or burned module from human factors are not in warranty scope. If products need factory maintenance, please return the main board together with the packing box and a note to clarify specific failure phenomenon.

## 4. Outdoor unit instruction

### 4.1 Structure and installation

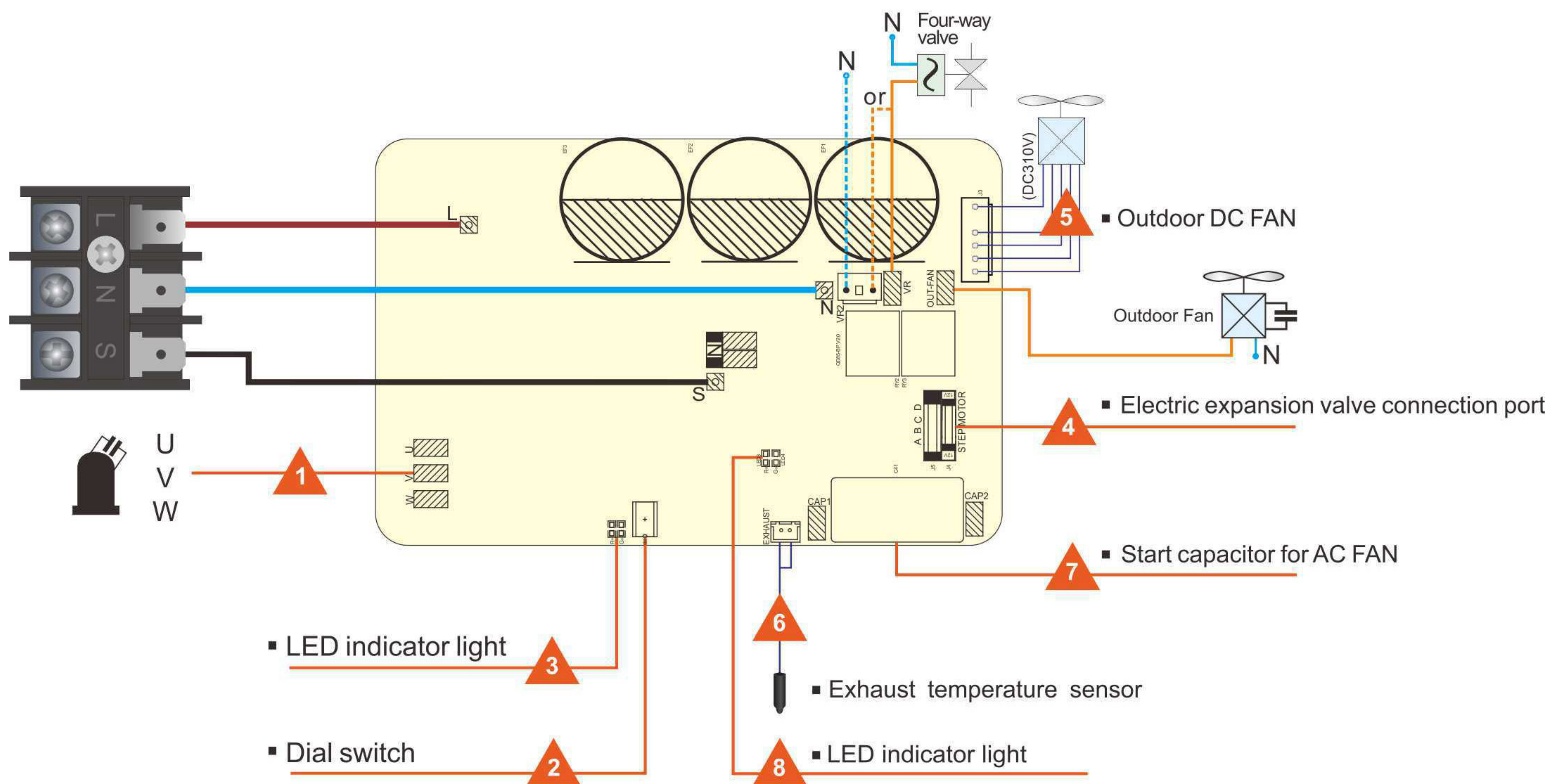

1) **U V W output terminal:** connect with the wires( U V W )of compressor correspondingly. if reverse rotation occur, please exchange two wires of them.

⚠ Before installation, please use the omh band of the multimeter to test the compressor and make sure the compressor coil is good and the resistance of three compressor feet is the same. If not, something may be wrong with the compressor. In that case, don't install the control system to avoid damaging it.

2) **Dial switch:** it has 3 gears to choose

**Gear1 is used to select DC inverter or AC inverter. as followings**

For AC inverter, please set gear1 to be ON side

For DC inverter, please set gear1 to number side

So before installation, please identify the compressor type(AC inverter or DC inverter)

**Gear2 and Gear3 is used to select the type of split air conditioner**

For the Maximum service power is 12000BTU, please set gear2 and gear3 to be both on number side

For the Maximum service power is 24000BTU, please set gear2 to ON side, and set gear3 to number side

For the Maximum service power is 18000BTU, please set gear3 to ON side, and set gear2 to number side

**Gear 4 is unused.**





# QD85U UNIVERSAL AC/DC INVERTER CONTROL SYSTEM FOR SPLIT AIR CONDITIONER

**3) LED Indicator light:** when the unit is working normally, For DC inverter, the green LED light will be on; For AC inverter, the green LED light will flicker. When failures occur, the green LED light will be off, at the same time, the red LED light will flicker. The red LED light will flicker differently according to the failure phenomenon. as followings:

• Outdoor unit trouble code meaning:

Red LED light flashing frequency	Trouble display (in display panel)	Trouble explanation
Once	E4	DC bus over voltage and undervoltage
Twice	E5	Over current protection
3 times	E6	IPM over current protection
4 times	E7	Over exhaust temperature
5 times	E8	Compressor rotor out-of-step trouble for DC inverter

• Note: when the outdoor unit shut-down alarm blows, identify trouble reasons and restart after power off to end the alarm.

## 4) Electric expansion valve installation

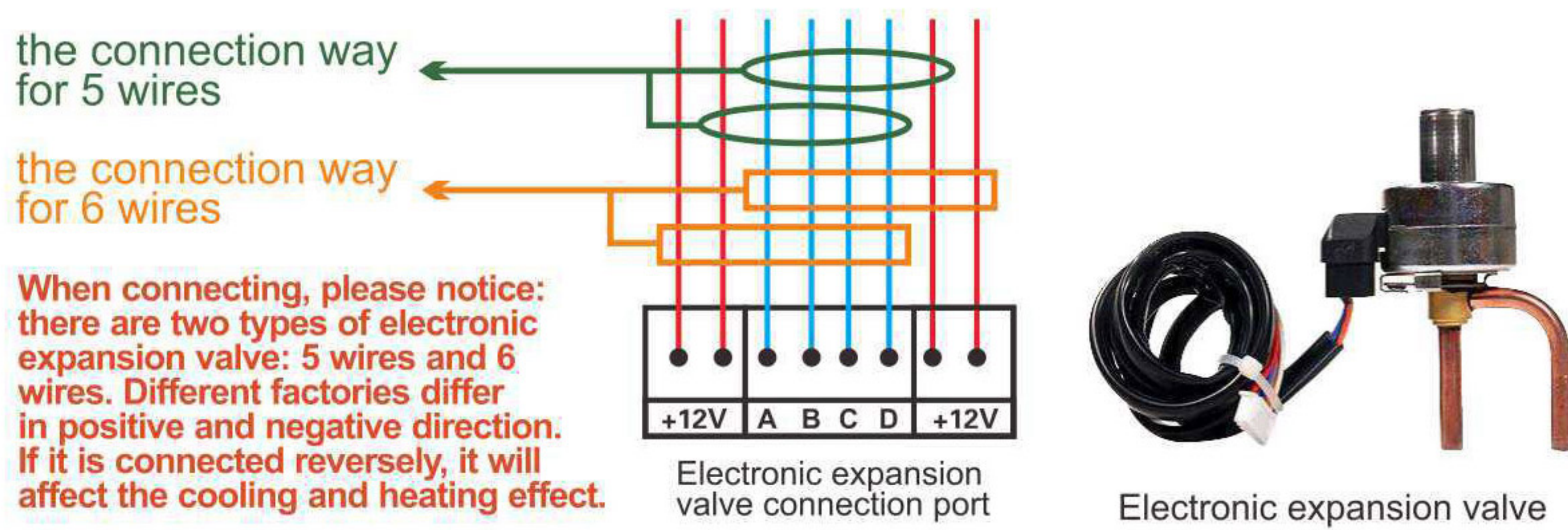

The way to confirm the positive direction of electronic expansion valve: When electrifying, before the compressor's running, the electronic expansion valve will reset, and it will turn off then turn on. Please connect a single electronic expansion valve, and make the coil and the valve body assembled correctly. After power on, blow air with your mouth. If you feel more and more difficult when blowing but it is still ventilated, which means the connection of electronic expansion valve is correct. If you can blow smoothly in the beginning but it is blocked finally, which means the connection direction is reversed. the common side of the valve should be connected to other common side of valve connection port.

## 5) Installation for outdoor DC FAN

If the outdoor fan is AC fan, this port is unused. If the outdoor fan is DC fan, connect the fan plug to this port. This port is for 5 wires DC fan motor, please make sure the line order correct as the flowing.

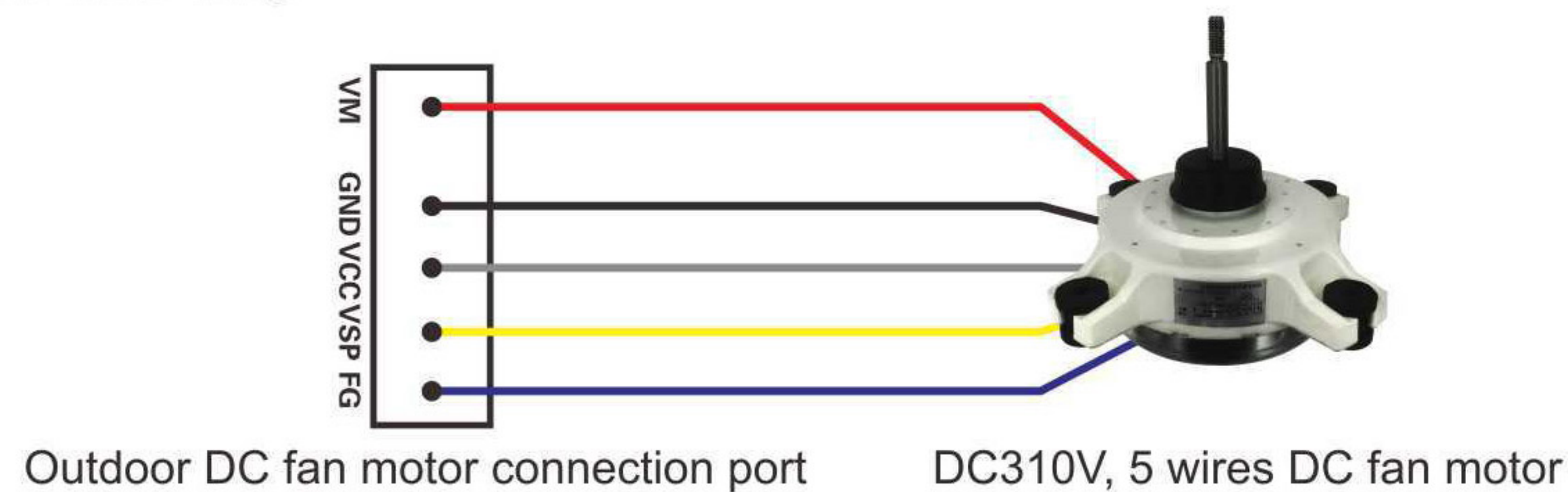

## 6) Exhaust temperature sensor connection port

when compressor exhaust temperature is higher than 110°C, it will shut down for protection.

## 7) Start capacitor

If the outdoor fan is three-wires AC fan. You need to connect CAP1 terminal to Null line, and connct CAP2 terminal to C(start) of AC Fan. If the outdoor fan is two-wires AC fan, the start capacitor is unused.

## 8) LED indicator light

When the Green LED light is on, it means compressor started. When the red LED light flashes, it means the communication between indoor and outdoor unit is failure.

⚠ Stabilize original heat sink with the original one through silicone grease to ensure better heat dissipation. And also use two screws to tighten up the two heat sinks.

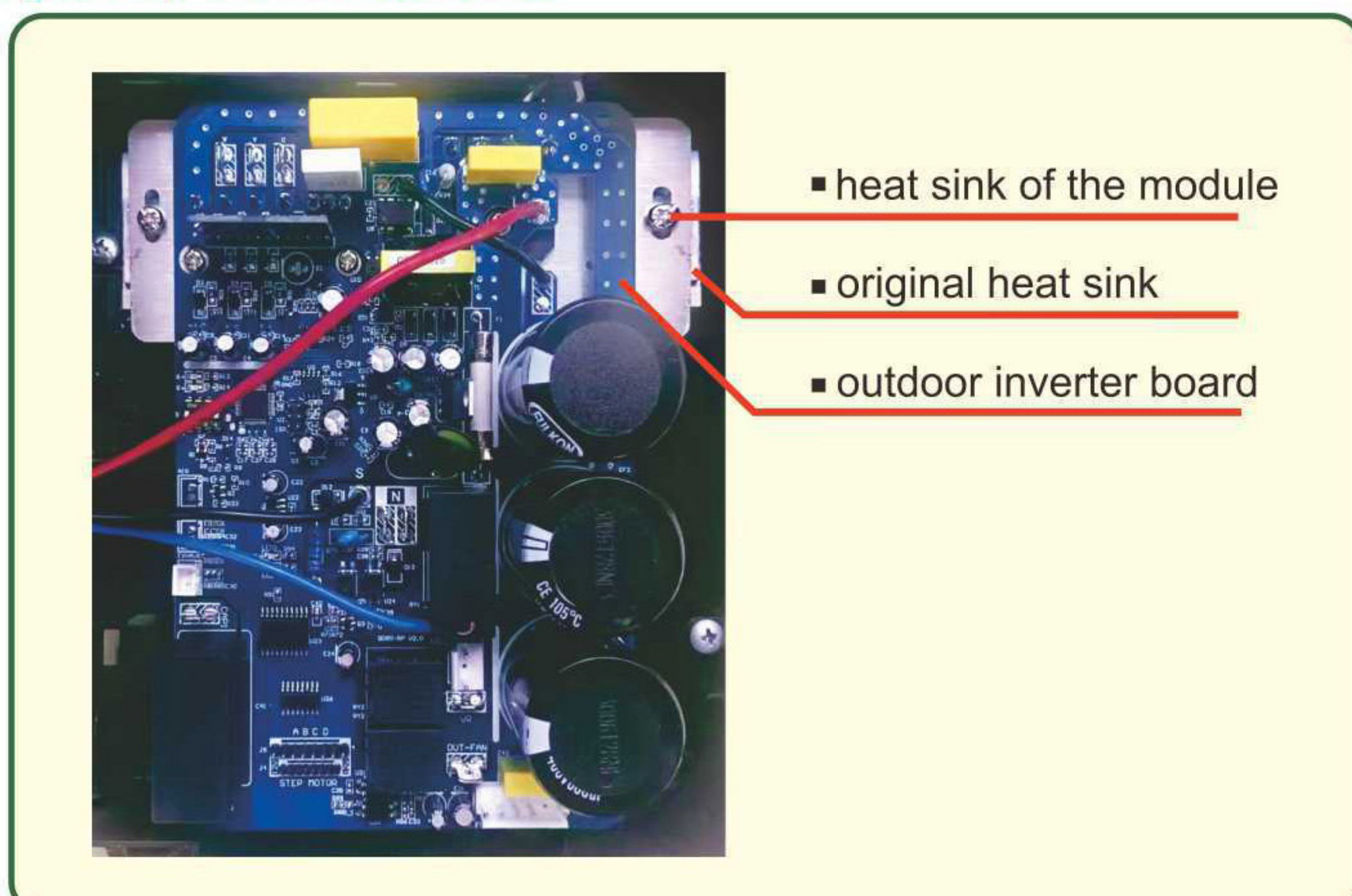

## 4.2 Technical parameters

Application scope	Split air conditioner
Maximum service power	24000BTU
Maximum input voltage	AC240V
Minimum input voltage	AC180V
Maximum output current	20A
Maximum output frequency	100Hz





# QD85U UNIVERSAL AC/DC INVERTER CONTROL SYSTEM FOR SPLIT AIR CONDITIONER

## 5. Indoor unit instruction

### 5.1 Indoor unit wire diagram and installation instruction

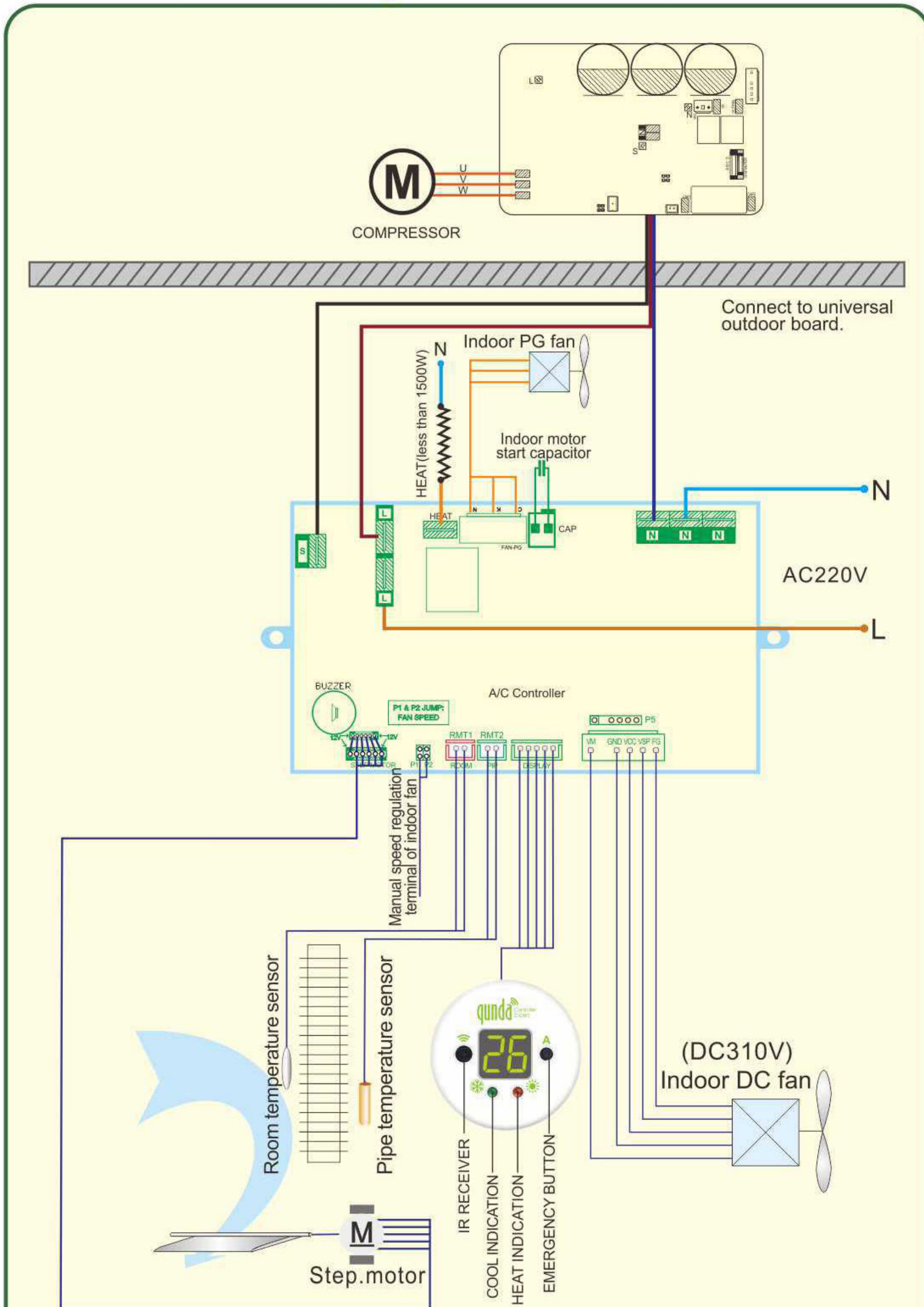

**Attention:**

1. The indoor board is applicable for PG fan and brushless DC fan, but they can not be used simultaneously.
2. Ensure there is no strong light in front of IR receiver.
3. The fan direction is controlled by stepper motor through STEP-MOTOR socket. The step motor output socket(STEP-MOTOR) has 6 pins. Two pins on both sides are common pins(12V). Either of them must connect with the common pin of motor plug that has 5 pins. If stepper motor rotating direction is reversed, the common pin of the motor plug should be connected to other common pin of stepper motor output socket.
4. DC fan motor connection port rule.

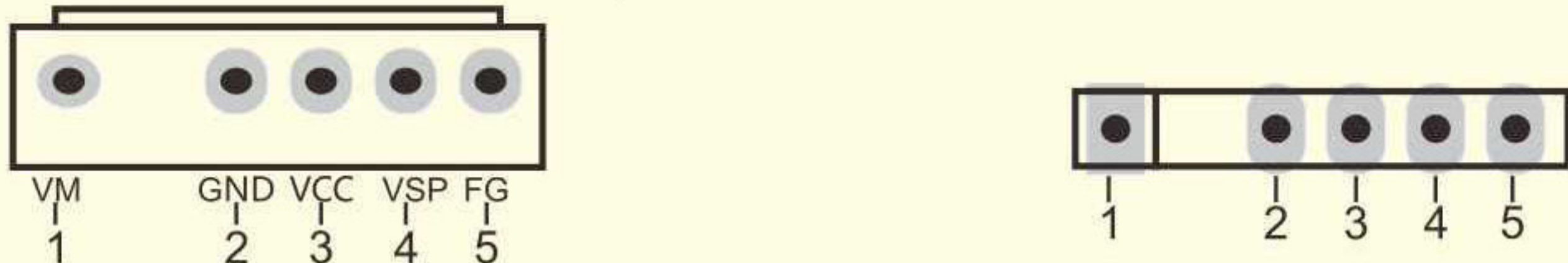

Name	Parameter	Description
1	VM	Fan power supply 310V
2	GND	Fan earthing terminal
3	VCC	Power DC 15V
4	VSP	Control voltage DC 0-6.5V
5	FG	Fan feedback

**5. Port explanation for P1 and P2**

P1 and P2 are the ports to manually adjust speed for brushless DC motor and PG motor. The default setting of P1 and P2 is under open circuit. After installation, if you find three fan speeds(high,medium,low) are all slower than the normal, refer the following diagram to adjust to the higher fan speed gear. Similarly, if you find three fan speeds(high,medium,low) are all faster than the normal, then adjust to the lower fan speed gear.

	P1 P2 situation	DC fan speed		PG fan speed	
Higher gear	P1 Short circuit P2 Open circuit	High speed	1600 r/min	High speed	218V
		Medium speed	1300 r/min	Medium speed	210V
		Low speed	1100 r/min	Low speed	200V
Default fan speed gear	P1 Open circuit P2 Open circuit	High speed	1340 r/min	High speed	195V
		Medium speed	1160 r/min	Medium speed	176V
		Low speed	880 r/min	Low speed	155V
Lower fan speed gear	P1 Open circuit P2 Short circuit	High speed	1200 r/min	High speed	182V
		Medium speed	1000 r/min	Medium speed	168V
		Low speed	800 r/min	Low speed	140V
Ultralow gear	P1 Short circuit P2 Short circuit	High speed	1000 r/min	High speed	143V
		Medium speed	800 r/min	Medium speed	118V
		Low speed	600 r/min	Low speed	95V

**Connect wires as the diagram shows if indoor PG motor plugs match**

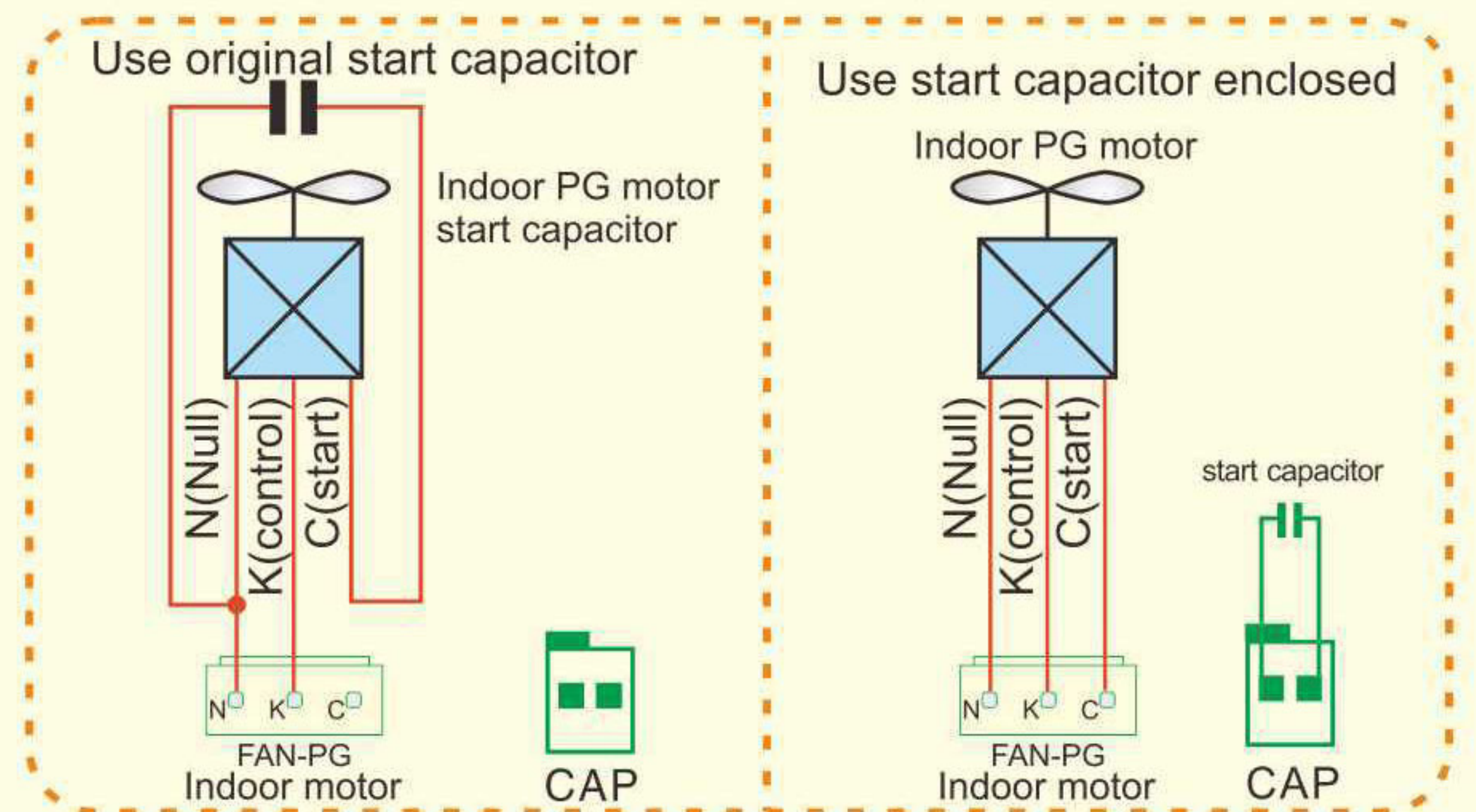

**Connect wires as the diagram shows if indoor PG motor plugs do not match**

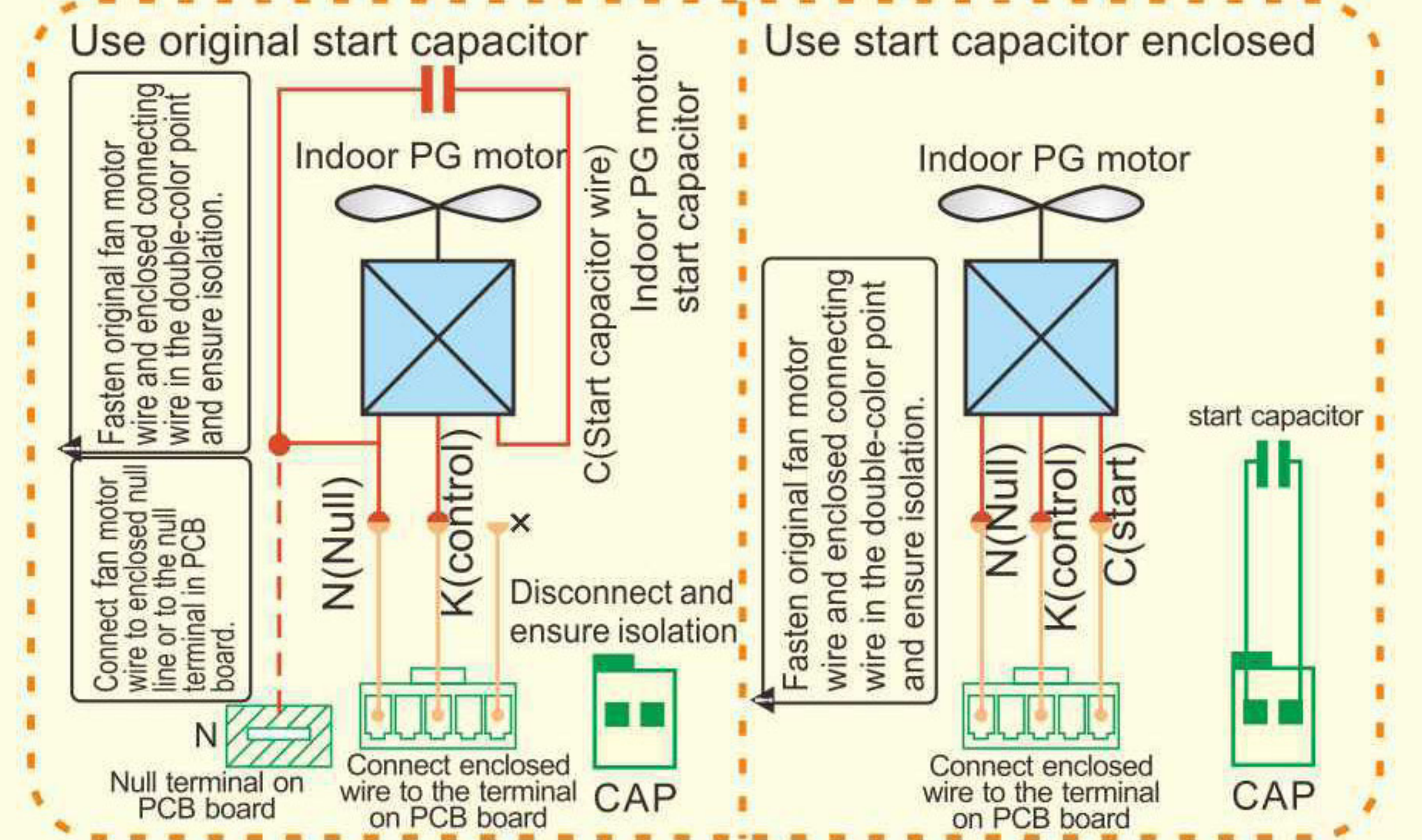

### 5.2 Indoor unit fault code meaning

trouble display (in display panel)	Trouble explanation
E1	Room temperature sensor trouble
E2	Indoor pipe temperature sensor trouble

### 5.3 Indoor unit display panel instruction

#### 1) MODE DISPLAY

- **AUTO MODE:** Temperature directories display "RU"
- **COOL MODE:** Cool indicator light on, temperature directories display setting temperature and room temperature, when setting it display setting temperature that by remote, and then display room temperature.
- **DRY MODE:** Temperature directory displays "dr"
- **VENTILATION MODE:** Temperature directory displays "FR"
- **HEAT MODE:** Heat indicator light on, temperature directory will display setting temperature and room temperature. When





# QD85U UNIVERSAL AC/DC INVERTER CONTROL SYSTEM FOR SPLIT AIR CONDITIONER

defrosting, temperature area displays “dF”, indicate that air-conditioner is in defrosting state.

- **SLEEP**: when in sleep mode, the luminance will be dark, make people have a good rest, setting temperature adjusts automatically and air conditioner shuts down after 8 hours.
- **TIMER ON**: Temperature area displays “ON” and flashes, it means air conditioner is in timer on mode.
- **TIMER OFF**: Temperature directory displays the current mode or temperature and flashes, it means air conditioner is in timer off mode.

## 2)REMARKS

- **IR receiver**: To receive the instruction from remote
- **Emergency button**: without remote, pressing this button can start air-conditioner. Press it to turn into cool mode, setting temperature will be 26°C, fan speed and direction will be automatical. Press again, it will turn into heat mode, setting temperature is 20°C, fan speed and direction will be automatical. Press again to turn off the air-conditioner. Circulating operation.

## 3)Compressor instruction

In heat or cool mode, when indicator light of heat and cool flashes, it means air-conditioner reaches the setting temperature, or compressor in 3 minutes protection state, compressor shut down now, when the indicator light on, it means compressor is on.

## 5.4 Indoor unit remote manual



- 1) **ON/OFF key**: press to turn on/ off the A/C.
- 2) **TEMP( temperature setting key)**: it can set the temperature from 16°C to 30°C. The key would not work under the auto or dry mode.
- 3) **Mode key**: working modes conversion (auto, cooling, dry, ventilation, heating). In the auto mode, the A/C would come to the heating mode when the room temperature is under 21°C; when the room temperature is higher than 27°C, the A/C would come to the cooling mode. The setting temperature is 24°C.
- 4) **Fan key**: fan speeds conversion. In the dry mode, the Indoor fan is low speed and works automatically: it is the high speed when

the temperature gap between the setting temperature and the room temperature is more than 4°C; 2-3°C is the middle speed; 2°C is the low speed. The wind speed would convert in every minute.

- 5) **26°C key**: 26°C key would set the A/C in the cooling mode and provide you the environmental-friendly and comfortable temperature.
- 6) **SWING key**: press to set the vane to swing or not.
- 7) **F. HEAT key**: 20°C key would set the A/C in the heating mode and provide you the environmental-friendly and comfortable temperature.
- 8) **SLEEP**: press to set the sleep mode. In the sleep mode, the fan coil would turn off automatically in 8 hours.
- 9) **TIMER**: press for timer on/off or cancelling the timer.
- 10) **TIME+ \ TIME-**: the time setting range from 1 to 16 hours.
- 11) **RESET**: press to reset the remote control.

## 6. Packing components

Item	Quantity	Unit
Universal indoor board	1	pc
Indoor unit sensors	2	pcs
Display panel	1	pc
fan motor wire	1	pc
plug-in start capacitor	1	pc
Remote control	1	pc
Universal outdoor board	1	pc
Four-way valve wire	1	pc
Compressor exhaust temperature sensor	1	pc
User's manual	1	pc
Packaged parts	1	pc

## Company information

**Name:** QUNDA Control Technology (Jiangsu) Co., Ltd.  
**Address:** No.888 LongQiao Road, WuJiang District, SuZhou, China  
**Post code:** 215200 **Web site:** www.qunda.net

★ Reserved the right of final explanation. Any alteration on the design and model will not be further notified.